

# INDUSTECH®

## AUTOMATIC STARTER PANEL (SMT MODEL)

### USER GUIDE



Factory Office : C-140, Sec. 10, Noida, Uttar Pradesh, India.  
 Corp. Office : 154/01, Chandar Nagar, Opposite SBI Alambagh, Lucknow.  
 Mob.: +918400900281  
 Varanasi Service Centre :  
 S 13/9-A, Sahu Katra, Teliyabagh, Varanasi. Mob.: 9415900517  
 e-mail:icaecohealth@gmail.com | www.industechms.com

**Customer Care No. : 7084499992**

1

## Water Level Management System FLC MODEL

**INDUSTECH**

### INSTALLATION AND OPERATING MANUAL

Carefully read and follow all safety instructions in this manual.

⚠️ Disconnect electrical power supply before installing or servicing Automatic Starter Panel.

⚠️ Make sure line voltage and frequency of power supply match this device nameplate voltage and frequency.

**⚠️ DANGER** Assure the quality of connection cables and wires. Cable should be protected at all times to avoid punctures, cut, bruises and abrasions - inspect frequently.

**⚠️ WARNING** This device should be installed and repaired by only electrical and electronic expert.

#### TABLE OF CONTENTS

- A. PREFACE
- B. SPECIFICATION OF SMT MODEL
  - i. SPECIAL FEATURES
  - ii. POWER SUPPLY
  - iii. INSTALLATION
    - a. CONNECTION LAYOUT
    - b. WIRING WITH STARTER PANNEL
    - c. WIRING WITH SENSOR
- C. TROUBL SHOOTING

#### A. PREFACE

This manual will provide you with the information to properly install and maintain the Automatic Starter Panel to ensure a long service and proper functioning. INDUSTECH Automatic Starter Panel is designed to sense and control most of the water pumps including Jet Pump and submersible pumps. It switches ON the motor when the water level in the overhead tank drops below a pre fixed level (Reserve point) and switches OFF the motor when the water level rises to another pre fixed level (Full point). It completely stops overflow of water from the over head tank or dry running of pump, thereby saving electricity and water. These losses can be prevented if the tank is regulated automatically by incorporating a feed-back control mechanism, which would be capable of tripping the pump ON or OFF as required.

2

#### B. SPECIFICATION

This device can be used in following application-

1. WATER IN: To fill Water tank.
2. WATER OUT: To empty the water tank.
3. DOUBLE TANK: To transfer water from one water tank to another.

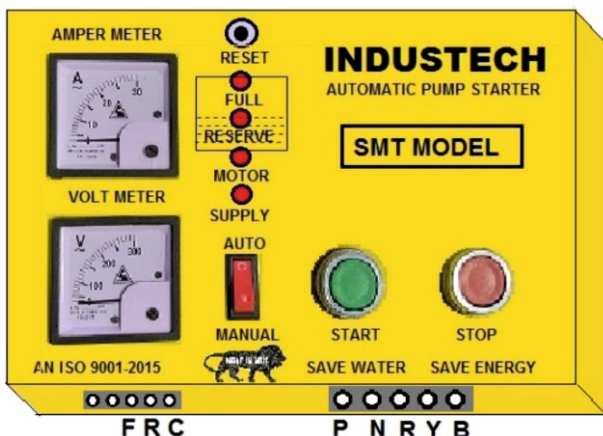

**Note:** For heavy pumps SMT Plus model is required.  
It is manufactured on demand only

#### Important Features

1. This model is suitable for single and three phase submersible pumps.
2. System has two mode operation "auto" mode and "manual" mode.
3. It protect pump from overload and dry run
4. Provided LED indication for MOTOR, RESERVE, SUPPLY and POWER.
5. Additional Protection from over voltage by Fuse and RESET Switch.

3

#### ii. Power Supply

INPUT	OUTPUT
220-250 Volt / 50 Hz AC	On Motor: 220 - 250 Hz AC Sensor : 12 Volt DC

#### iii. INSTALLATION

##### (a) CONNECTION LAYOUT WITH PUMP

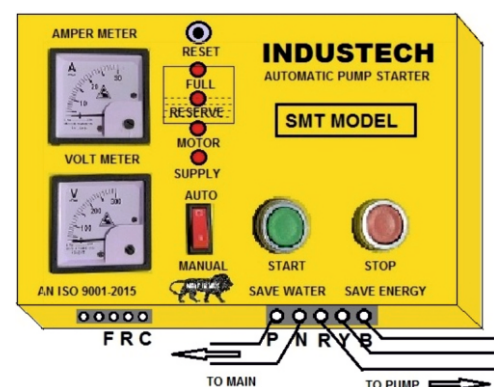

**Warning:** Switch off main supply before starting installation to avoid any accident

#### Connection Terminals

1. Power terminal has two points P(Phase) and N(Neutral) get connected to 220V – 250 V AC.
2. F(Full), R(Reserve) and C (common) will be connected with Sensor wire.
3. Points of RYB terminals of starter will be connected with the RYB Terminal of Pump.
4. RESET switch prevent overloading of pump and starter.
5. Manual switch' is used to operate pump manually

4

### C. WIRING with SENSOR

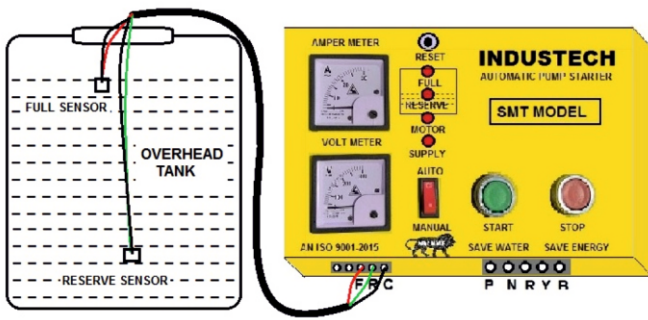

#### Steps of Connection

1. Use three core multicolour shielded cable.
2. Now connect different wire of different colour with C Common, R (Reserve), F(Full) points on sensor terminal.
3. Connect F and C point wire with sensor to be placed on full level on over head tank.
4. Now connect C and R point wire with reserve sensor and place it on Reserve Level of Over head tank

5

### TROUBLE SHOOTING

We have paid full attention to minimize complain. Being electronic device some fault may happen.

Before going to trouble shooting it is compulsory to discuss different LED indicator since these indicator provide information about the proper operation of various sections of device.

1. **Power LED:** It indicates presence of power in device.
2. **Full LED:** When Overhead tank gets filled it Glows and device stop the pump.
3. **Reserve LED:** When water level reaches reserve level it glows and pumps starts.
4. **Motor LED:** It indicates the running status of Pump.
5. **Water Source LED:** It indicates presence of water in supply.

With the help of these indicators most of the faults can be determined. Some problem are being discussed bellow.

i. **Problem :** All the LED glow but motor do not stop

**Solution:** Above condition Shows that devise is on manual condition. As soon it will be changed to auto mode

6

pump will stop immediately.

ii. **Problem:** POWER, FULL. RESERVE, RESEVE and SUPPLY LED is ON and MOTOR LED is OFF but motor continue to run.

**Solution:** It shows that there is fault in contactor of starter panel and immediately change it.

iii. **Problem:** If FULL LED, MOTOR LED, glow but RESERVE LED is OFF and motor continues to run.

**Solution:** It shows that sensor wire may be damaged or sensors are not working properly

iv. **Problem:** When RESERVE LED, MOTOR LED, and SUPPLY LED is on and FULL LED is OFF and pump continue to run.

**Solution:** It shows that either sensor wire is damaged or FULL sensor is not working.

v. **Problem:** If FULL LED, RESERVE LED is ON and over head tank get empty but motor do not start.

**Solution:** It shows that either wire is damaged or sensor is not working

7



Factory Office : C-140, Sec. 10, Noida, Uttar Pradesh, India.

Corp. Office : 154/01, Chandar Nagar, Opposite SBI Alambagh, Lucknow.

Mob.: +918400900281

Varanasi Service Centre :

S 13/9-A, Sahu Katra, Teliyabagh, Varanasi. Mob.: 9415900517

e-mail : icaecohealth@gmail.com | www.industechms.com

8